



blue photon®

Technology & Workholding Systems LLC

Adhesive Workholding
User Guide



Adhesive Workholding User Guide

Blue Photon Technology & Workholding Systems can help you simplify workholding for difficult to hold or delicate parts while improving tolerances and part access, reducing scrap, and eliminating extra processes.

This user guide was written for the users of Blue Photon's workholding technology. Before you use, read this manual carefully. In particular, pay attention to the warnings and cautions that appear in the safety and design sections at the front of the manual. Before you begin, you should also read the maintenance instructions. For more information, see Maintenance, page 10. Visit our website for the most up-to-date product and safety information: www.BluePhotonGrip.com.



Table of Contents

Glossary	2
Caution	3
Personal Protection Equipment (PPE)	3
System Considerations	3
Instructions	4-8
Design Considerations	9
Maintenance	10
Technical Data.....	10-12
Troubleshooting.....	13

Sales and Engineering Support
Blue Photon Technology & Workholding Systems LLC
1002 Industrial Park Dr., Shelby, MI 49455
855-777-2040 • sales@BluePhotonGrip.com



WARNING
Do not use the Blue Photon workholding system to hold overhead loads. The Blue Photon workholding system is not designed to support people. Never stand under a lifted fixture and/or part. If insufficient holding strength to resist cutting forces; or if improperly used, a workpiece may be ejected from the fixture at a high rate of speed. Always follow employer work instructions and Blue Photon user guide recommendations to minimize any risk. Always use proper guarding to protect people from injury due to a workpiece coming dislodged from the fixture.

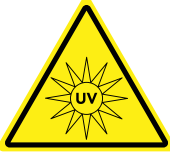

IMPORTANT
Before using the ultraviolet (UV) LED equipment read and understand all manufacturer's documentation for proper setup, safety and necessary maintenance.
****Caution**** Do not stare directly at the light emitted from the LED head. This may be harmful, resulting in eye injury.
Always use UV protective eyewear.

Glossary

Term	Definition
Adhesive Dispenser	A device used to dispense adhesive in a semi- or fully automated fashion.
Axial Grinder	A Blue Photon spindle mounted tool used to remove cured adhesive in a machining center when the gripper axis is parallel to the spindle axis.
BlueGrip™ Workholding Adhesive	An adhesive designed specifically for Blue Photon's workholding applications.
Gripper	A load bearing, light transmitting fixture component.
Gripper Insert	A Blue Photon tooling component used to hold and offset a gripper.
PAAW	Photo activated adhesive workholding.
PPE	Personal protective equipment.
Radiometer	A device used to measure electromagnetic radiation.
Transfer Tool	A fixture designed to hold a part relative to a nest but as a separate tool, equipped with a zero-point locating system.
UV	Ultraviolet.
UV LED Head	A device that emits ultraviolet light.



CAUTION

This guide as well as additional manuals provide a description of the function, application and safety considerations of the Blue Photon system. These manuals must be read and understood before any attempt is made to install or use this system. Improper use could result in damage to the product or unsafe conditions for the user. Follow these safeguards to prevent serious injury or property damage. Consult the factory on turning applications.



DESIGN CONSIDERATIONS

This guide provides general operating procedures. Your specific application will have special considerations in setup, function and use. There are several design considerations that must be addressed before implementing Blue Photon workholding. Review these considerations with your design and engineering teams, including the number and position of grippers, adhesive joint temperature, adhesive cure time, amount of adhesive, setting the part on applied adhesive, and part and gripper cleaning.

Adhesive Workholding User Guide

Caution



Blue Photon's technology has been tested in industry and academia to help ensure a safe and reliable end product. However, as with any workholding system, there are many variables that may cause unforeseen challenges. A thorough understanding of good manufacturing practices is the responsibility of the end user.

Read and understand this user guide and all supplemental materials provided by third party companies pertaining to the safe use of all items used in the Blue Photon workholding system. Read warnings on workholding adhesive labels before using.

The Blue Photon system uses UV light which emits harmful optical radiation. Protection for the user and people in the surrounding area is required. Consult the UV light controller manual for further important safety information. Never stare directly at the UV light.

If using hot water or steam to clean the part, always take appropriate steps to assure safe interaction with hot water/steam.

If the system is stressed beyond the holding power of the BlueGrip workholding adhesive or if the part is adhered without following the proper procedures outlined in this document it is possible to throw a work piece. Steps should be taken to eliminate the risk to people or property of a thrown workpiece. Always consult a safety expert in the field to evaluate the potential risk if you are unsure of how to best protect individuals and/or property. Consult the factory on turning applications before proceeding with the Blue Photon technology.

Personal Protection Equipment (PPE)

Before you start make sure the following PPE is in place:

- UV light blocking goggles, glasses or shield for anyone within 6 ft of the adhesive curing area.
- Wear leather gloves or similar light blocking gloves if the UV LED heads are not inserted into a fixture when turned on.
- Wear long sleeves if the UV LED heads are not inserted into a fixture when turned on.
- Rubber gloves when handling alcohol or uncured adhesive.

Use a Handheld Radiometer (P/N 62020) to verify that no stray UV is escaping from the work area where people are present.

System Considerations

– Workpiece and gripper cleanliness

Be sure part and grippers are free of dirt, oil or grease.

– Joint temperature

The temperature of the adhesive joint can affect the holding power of the system. Use coolants with materials that transfer heat. Refer to the adhesive performance charts in the back of this guide.

– Materials

Some plastics may result in weaker bond strengths than harder, more dense materials. Contact Blue Photon for more information and assistance with testing the holding power on various materials.

Instructions

Important: Before using the UV LED equipment read and understand all manufacturer's documentation for proper setup, safety, and necessary maintenance.



1. Installing the gripper adapters to the UV LED heads

The adapters protect the UV LED heads and provide an accurate alignment to the back of the gripper.

- **Small Gripper Adapter**
The adapter is screwed onto the UV LED head.
- **Medium Gripper Adapter**
UV LED head is inserted and pushed into the adapter until the head stops, then tighten the set screw to lock in place.*
- **Large Gripper Adapter**
UV LED head is inserted into the adapter until the head is flushed, then tighten the set screw to lock in place.*

***Caution:** Do not over tighten the set screw.

Adhesive Workholding User Guide

Instructions cont.

2.1 Setting up the BlueCure Mini 4 | UV LED head controller

Setup: A Mode: UV Power 100%

Irradiation time 060.0s

CH1	100% A	060.0 S	Left: CH1~CH4 is the
CH2	100% A	060.0 S	UV Channel Number
CH3	100% A	060.0 S	Middle: UV Power / Irradiation Mode
CH4	100% A	060.0 S	Right: Irradiation Time

1. Turn the controller power switch on.
2. Turn the key switch on, located on front of control panel.
3. Press the "Run / Stop" button.
4. Press the "Set" button to enter into parameters setup mode.
5. Press "←" and "→" button to move cursor "_" to the irradiation mode.
6. Press "↑" and "↓" button to change it to A mode.
7. Press "←" and "→" button to move cursor "_" to the UV power.
8. Press "↑" and "↓" button to change it to 100%.
9. Press "←" and "→" button to move cursor "_" to the irradiation time.
10. Press "↑" and "↓" button to change it to 060.0s.
11. Press the "Ent" button to save parameters.
12. Turn the key switch off and remove key.
13. Start the UV light source by pushing "Ent".

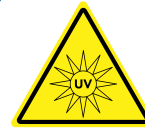

CAUTION

Do not stare directly at the light emitted from the UV LED head. This may be harmful, resulting in eye injury. Always use UV protective eyewear.

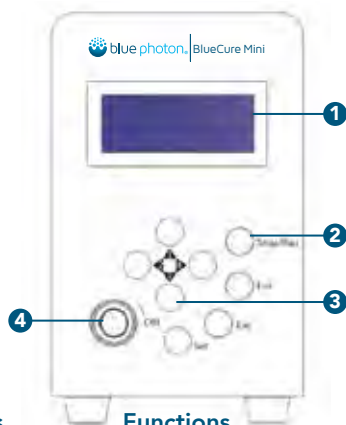

Front Panel

No.	Modules	Functions
1.	LCD	Display Running Parameters
2.	Set / Esc / Ent / Stop / Run	Setting Buttons
3.	Arrow Buttons	Setting Buttons and UV LED Head Control Buttons
4.	Key Switch	Turn On the Switch Before Setting Turn Off the Switch After Setting

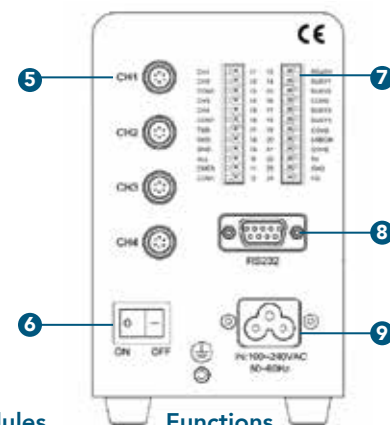

Back Panel

No.	Modules	Functions
5.	UV Output Channels	Connect the UV LED Heads
6.	Power Switch	Turn On / Off the Controller
7.	Signal Ports	Input and Output Signal
8.	RS232	Input and Output Signal
9.	A/C Input Socket	Power Input: 100~240V AC 50~60Hz

Instructions cont.

2.2 Setting up the BlueCure 8 | UV LED head controller

Setup: A Mode: UV Power 100%
Irradiation time 060.0s

1. Turn the controller power switch on.
2. Press "Settings" button.
3. Enter the password: 1234, press ok.
4. Press the "CH1" button, select auto tab.
5. Select and type "100%" to change intensity.
6. Select and type "60.0s" to change the irradiation time.
7. Press start up tab, and set the controller to pulse and linkage.
8. Press "Save Settings".
9. Press "Yes".
10. Repeat steps above for the additional UV channels.
11. Press "Return".
12. Once UV channels are setup, touch right column to turn UV LED controller on for CH1~CH8 light heads to begin the curing process.
13. At the end of 60.0s, UV LED controller light heads will automatically shut off with a chirp.

Left: CH1~CH8 is the UV Channel Number

Middle: UV Power / Irradiation Mode

Right: Irradiation Time / Temp

Light	Mode	Intensity	Time	Temp
CH1	A I P	100%	60.0s	°C
CH2	A I P	100%	60.0s	°C
CH3	A I P	100%	60.0s	°C
CH4	A I P	100%	60.0s	°C
CH5	A I P	100%	60.0s	°C
CH6	A I P	100%	60.0s	°C
CH7	A I P	100%	60.0s	°C
CH8	A I P	100%	60.0s	°C

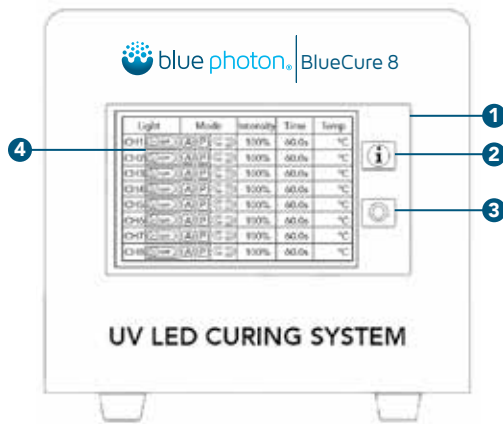

Front Panel No.	Modules	Functions
1.	LCD	Display Running Parameters
2.	Information	Controller Information Button
3.	Settings	Setting Buttons and UV LED Head Control Buttons
4.	UV Channels On and Off Button	Scroll Right to Turn UV LED Controller On for CH1-CH8 Heads to Begin Curing Process.

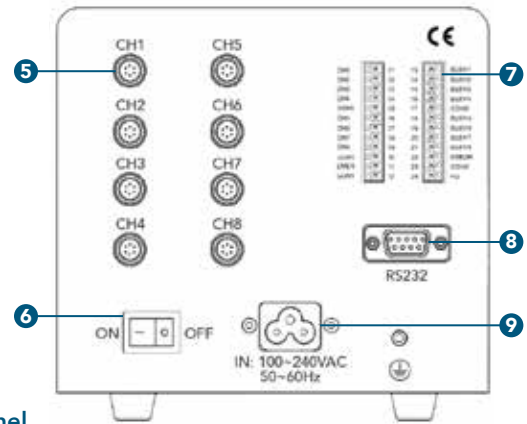

Back Panel No.	Modules	Functions
5.	UV Output Channels	Connect the UV LED Heads
6.	Power Switch	Turn On / Off the Controller
7.	Signal Ports	Input and Output Signal
8.	RS232	Input and Output Signal
9.	A/C Input Socket	Power Input: 100~240V AC 50~60Hz

Adhesive Workholding User Guide

Instructions cont.

3. Bond your part

1. First clean your workpiece and grippers of any dust and debris by swiping with 90% pure or greater isopropyl alcohol or another cleaning agent. Do not use an abrasive cleaner or cloth on the grippers. See Step 3a below.
2. Apply the required amount of BlueGrip™ workholding adhesive to the face of each of the grippers. The ideal gap is 0.02 (0.50 mm) for small grippers and 0.04 inches (1.02 mm) for medium and large grippers. See Step 3b below.
3. Place the part onto the fixture using care not to smear or scrape off the adhesive that has been applied to the face of the grippers. See Step 3c below.
4. Insert the LED heads into fixture. See Step 3d below.
5. Start the UV light source. Consult with your design and engineering team for specific process parameters and configuration. BlueGrip workholding adhesive cures in 60 to 90 seconds. See Step 3e below.
6. Remove heads and repeat if more grippers need curing.
7. Your part is ready for machining. See Step 3f below.

Step 3a



Clean dirt and oil from the grippers and workpiece.

Step 3b



Apply enough adhesive to the grippers to fully fill the gap between the part and gripper.

Step 3c



Position the part onto locators.

Step 3d



Insert LED heads into fixture.

Step 3e



Polymerize the adhesive by applying UV light for 60 to 90 seconds.

Step 3f



Machine the workpiece.

Instructions cont.

4. Release the part

The part is released from the grippers with a 1/4 turn twist of the grippers or by a hot water soak.

- Twist debond - twist the gripper 1/4 turn counter-clockwise to shear the adhesive bond. See Step 4 below. *Retighten the grippers after debonding.*
- Soak debond - soak the part and fixture in hot water (at least 180°F (82.2°C)) for 3-5 minutes then pull the part off the grippers. Increasing the temperature of the water decreases the required soak time.

Step 4



Separate fixture from workpiece with a 1/4 turn twist or hot water soak.

5. Cleaning cured adhesive

- Cleaning tool - To remove residual, cured adhesive from the grippers use our spindle mounted cleaning tool (P/N 82400) in your CNC machine along with the included program (formatted for Haas controls). See Step 5a below.
- Hot water - To remove residual, cured adhesive from the part and/or gripper use hot water with a pressurized spray to weaken and strip away the cured adhesive. See Step 5b below.
- Steam - An application of pressurized steam will soften the adhesive enough to peel it away. See Step 5c below.
- Dry ice blasting - A cold jet application will remove residual cured adhesive from the part as well.

Step 5a



Loaded in CNC machine spindle (P/N 82400) to remove cured adhesive.

Step 5b



Spray the part and fixture with hot water.

Step 5c



Remove residual adhesive with steam or hot water spray.

Adhesive Workholding User Guide



Design Considerations

These are some of the considerations to address when you implement the Blue Photon workholding system.

Adhesive Joint Temperature

As the temperature of the adhesive joint increases the bond strength decreases. Please refer to the adhesive performance charts in the technical data section of this guide.

Bond Time

60-120 seconds is the maximum amount of time required to cure the BlueGrip workholding adhesives. Shorter cure time is possible depending on the bond strength required, the adhesive gap thickness and size of gripper used.

Adhesive Gap Thickness

The adhesive gap is the thickness of the adhesive between the workpiece and gripper face. The Blue Photon workholding system recommends using an adhesive gap of 0.02 (0.50 mm) to 0.12 inches (3.05 mm). The ideal gap is 0.02 inches (0.50 mm) for small grippers and 0.04 inches (1.02 mm) for medium and large grippers.

Amount of Adhesive

The entire adhesive joint between gripper face and part needs to be filled with adhesive completely for consistent results.

Part Loading

Do not allow the part to scrape off the adhesive from the grippers as the part is loaded.

Removing Cured Adhesive from the Part and Grippers

Hot water soak, hot water pressure washer or steam can be used. A minimum water temperature of 180°F (82.2°C) is recommended. Hotter water reduces time and effort required to remove cured adhesive. Grippers can be cleaned by a CNC gripper cleaning tool mounted into the CNC if desired.

Part and Gripper Cleanliness

Parts and grippers need to be free of contaminants that would hinder adhesion, such as oils, grease or dirt.

Transfer Tool

A transfer tool is used to transfer the part datums from the part to a quick change machining fixture, and can have permanent, temporary or no part datums and is designed to carry the machining load. If the transfer tool contains part datums and multiple transfer tools are used, then each transfer tool will have to be precision machined and maintained to eliminate feature variation due to tool build. On the other hand, if the part datums are contained in the bond station (see below) then the transfer tool does not need to be precision made as the datum locators are contained in the bond station.

Bond Station

A fixture that transfers the part datums to a quicker change zero-point fixture system accurately and repeatedly.

Maintenance

Daily maintenance:

- Always clean grippers prior to every use with alcohol or similar cleaning agent.
- Check both ends of grippers to verify that they are optically clear and free of defects.

Technical Data: Gripper Installation

Metric

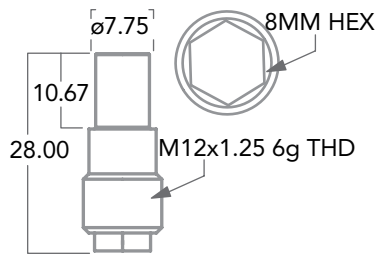

P/N 14130/14131 Gripper

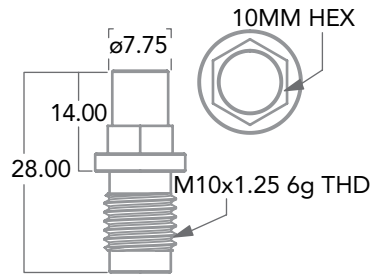

P/N 14230/14231 Gripper

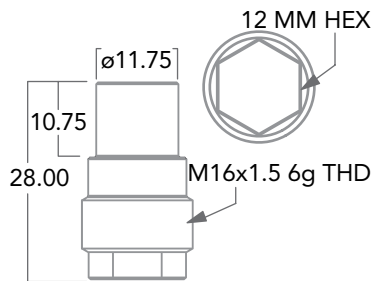

P/N 15130/15131 Gripper

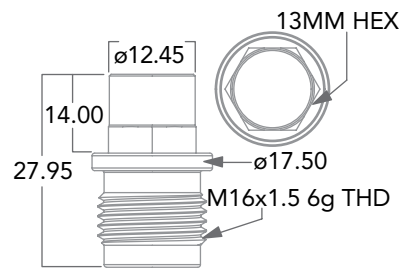

P/N 15230/15231 Gripper

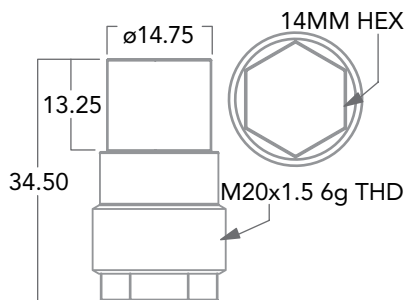

P/N 16160/16161 Gripper

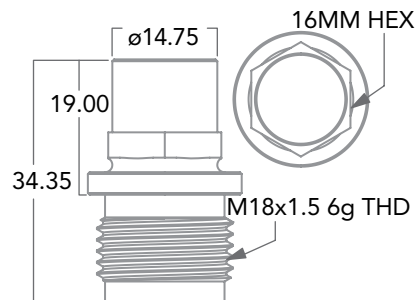

P/N 16260/16261 Gripper



Fixture hole geometry



Fixture with gripper installed

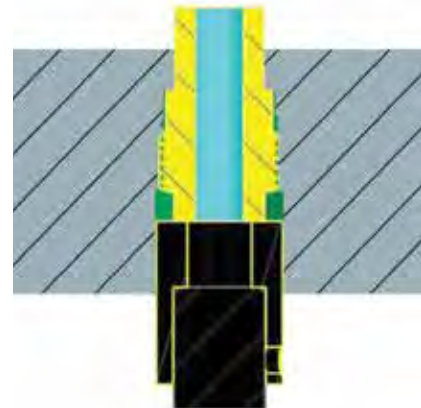

Fixture with gripper, LED head and adapter

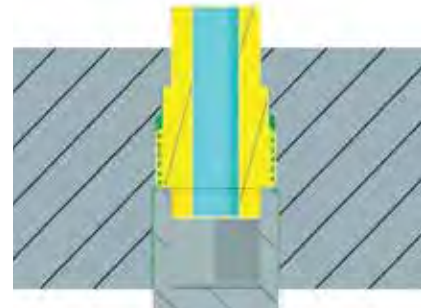

Fixture with gripper and thin walled socket

Adhesive Workholding User Guide

Technical Data: Gripper Installation cont.

Metric

Values (meters) of Geometric Parameters for Fixture Mounting

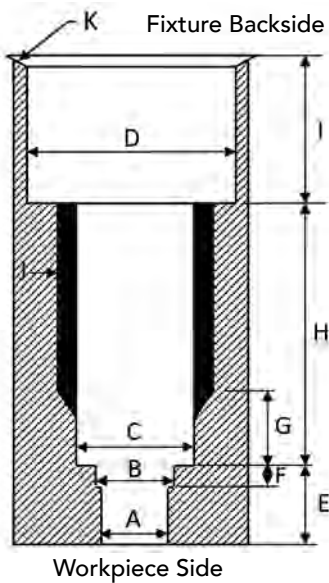

Parameter	14130/14131	15130/15131	16160/16161
A	7.900 + .075/-0.025	11.900 + .075/-0.025	14.950 + .075/-0.025
B	8.250 + .105/-0.0	12.250 + .105/-0.0	15.250 + .105/-0.0
C	10.8 mm	14.5 mm	18.5 mm
D*	12.300 +/-0.050	16.755 +/-0.050	20.000 +/-0.050
E	3.100 MIN	5.000 MIN	5.000 MIN
F	.375 + .63/-0.125	.375 + .63/-0.125	.375 + .63/-0.125
G**	4.500 MAX	4.500 MAX	4.500 MAX
H	13.450 +/-0.375	13.450 +/-0.375	17.250 +/-0.375
I*	7.000 MIN	7.000 MIN	7.000 MIN
J	M12x1.25 6H	M16x1.5 6H	M20x1.5 6H
K	.500 x 45°	.500 x 45°	.500 x 45°
MAX Tightening Torque***	13.6 Nm	20.4 Nm	27.2 Nm

*Necessary if a LED head adapter is to be used (see catalog).

Relates to full thread. *Do not over tighten the grippers.

Technical Data: BlueGrip™ Workholding Adhesive

BlueGrip workholding adhesive performance: axial/shear strength versus temperature.

Joint strengths achieved with:

- Medium Head-In Gripper P/N 15130.
- Joint thickness of 0.060 inches (1.52 mm).
- Cure time of 60 seconds.

BlueGrip™ S2 Axial Strength vs. Temperature

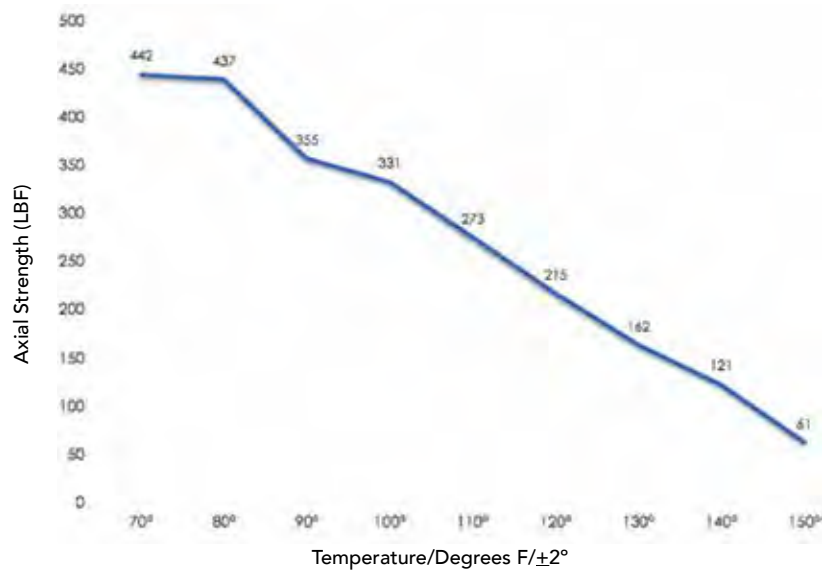

BlueGrip™ S2 Shear Strength vs. Temperature

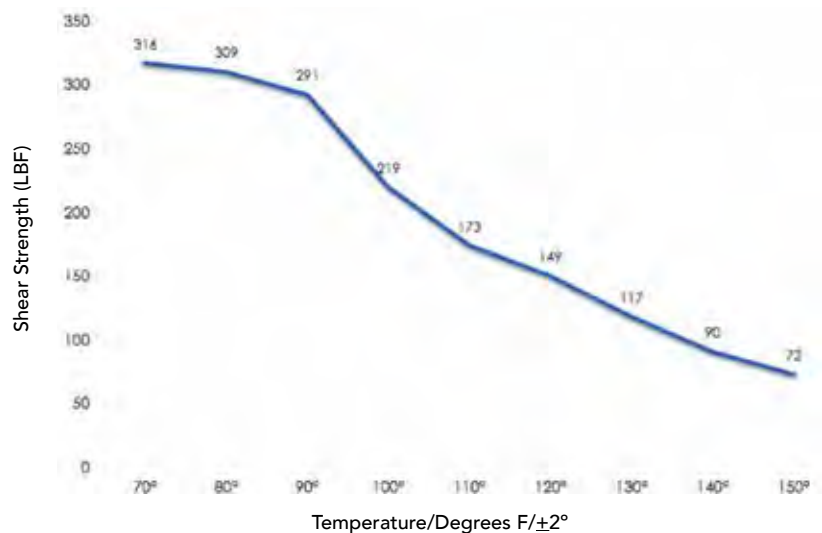

Adhesive Workholding User Guide

Troubleshooting

Problem	Description	Solution
Weak adhesive bond.	Insufficient UV light or intensity to cure adhesive fully.	Check UV output with sensor unit.
	Adhesive has expired.	Replace with adhesive that is within recommended shelf life.
	Gripper is damaged or unclean.	Ensure grippers and work/part are clean and free of defects.
Inconsistent results or part coming dislodged during machining.	All grippers are not exposed to UV light.	Verify that all grippers are exposed to UV light.
	Gap between workpiece and gripper is incorrect.	Verify that the gap between the gripper face and the workpiece is within required specifications.
	Amount of adhesive applied is not appropriate.	Be sure that the entire gripper face is covered and the gap between the gripper face and workpiece is completely filled.
	Position of grippers is wrong.	Reposition grippers to more evenly support workpiece.
	Inadequate number of grippers to counteract machining forces.	Add additional grippers.
	Material and/or grippers not cleaned properly.	Allow time for cleaner to evaporate.
	Bond joint temperature too high.	Bond joint temperature can weaken bond. Take steps to cool the adhesive joint.
	Material not compatible.	Consult Blue Photon for adhesive compatibility with your particular material.
Workpiece to transfer tool locating not repeatable.	Workpiece loading to nesting points must be repeatable. Check bond station and transfer tool/part clamping.	



www.BluePhotonGrip.com • 855-777-2040
1002 Industrial Park Dr., Shelby, MI 49455

©2023 Blue Photon Technology & Workholding Systems LLC. All Rights Reserved. Blue Photon has made every effort to ensure the accuracy of the product information in this document; however, we are not responsible for typographical discrepancies. Actual products may vary from those shown in photos. Refer to our website for current product and safety information. Blue Photon User Guide V3.2 10745 11.02.23